

SENSYLINK Microelectronics

(CHT8310)

Low Voltage Digital Humidity & Temperature Sensor

CHT8310 is a Low Voltage Digital Humidity and Temperature Sensor with typical accuracy of $\pm 2\%RH$ and $\pm 0.2^{\circ}C$. It is compatible with SMBus, I²C Interface. It is ideally used in HVAC, environment monitor etc.

Low Voltage Digital Humidity and Temperature Sensor

Table of Contents

DESCRIPTION	4
FEATURES.....	4
APPLICATIONS	4
PIN CONFIGURATIONS (TOP VIEW).....	4
TYPICAL APPLICATION	4
PIN DESCRIPTION	5
FUNCTION BLOCK	5
ABSOLUTE MAXIMUM RATINGS (NOTE1).....	7
RECOMMENDED OPERATING CONDITIONS.....	7
ELECTRICAL CHARACTERISTICS (NOTE2).....	8
1 FUNCTION DESCRIPTIONS	12
1.1 REGISTER MAP (NOTE3)	12
1.1.1 <i>Temperature Measurement Data</i>	12
1.1.2 <i>Relative Humidity Measurement Data</i>	14
1.1.3 <i>Config Registers</i>	14
1.1.4 <i>Conversion Setup Register</i>	16
1.1.5 <i>High/Low-limit Alert Setup for temperature and humidity</i>	16
1.1.6 <i>One-shot Register</i>	16
1.1.7 <i>Manufacture ID</i>	16
1.2 ALERT OUTPUT	16
1.2.1 <i>Interrupt mode (ATM = 0)</i>	17
1.2.2 <i>Comparator mode (ATM = 1)</i>	17
1.3 DO MEASUREMENT PROCEDURE.....	18
1.3.1 <i>Step 1, setup the sensor working mode via Config, Conv_Rate registers</i>	18
1.3.2 <i>Step 2, read out temperature and/or humidity measurement data</i>	18
1.4 DIGITAL INTERFACE.....	18
1.4.1 <i>Slave Address</i>	18
1.4.2 <i>Timeout</i>	18
1.4.3 <i>SMBus Alert Response Address (ARA)</i>	18
1.4.4 <i>General Call</i>	19
1.4.5 <i>High Speed Mode</i>	19
1.4.6 <i>PEC</i>	19
1.4.7 <i>Read/Write Operation</i>	20
2 APPLICATION INFORMATION.....	20
2.1 TYPICAL APPLICATION IN HARDWARE.....	20
2.2 PCB LAYOUT.....	21
2.2.1 <i>Device placement</i>	21
2.2.2 <i>Cin, Pull-up resistor</i>	21
2.3 IMPORTANT NOTICES.....	22
2.3.1 <i>Soldering</i>	22
2.3.2 <i>Cavity Protection Cover</i>	22
2.4 SOFTWARE REFERENCE CODE.....	23
PACKAGE OUTLINE DIMENSIONS (DFN3X3-6).....	27
RECOMMEND LAND PATTERN LAYOUT (DFN3X3-6)	28
PACKING INFORMATION	29
REVISION HISTORY.....	30

Figures and Tables

Figure 1. Typical Application of CHT8310.....	4	Table 1. Register Maps Definition.....	12
Figure 2. CHT8310 function block	5	Table 2. 13-bit Temperature Data (EM bit = 0)	13
Figure 3. I ² C Timing Diagram	9	Table 3. 14-bit Temperature Data (EM bit = 1)	13
Figure 4. SMBus ALERT Response Diagram	9	Table 4. 16-bit humidity data	14
Figure 5. SMBus/I ² C 2-Byte Write Timing Diagram.....	9	Table 5. Alert trigger source setup.....	15
Figure 6. SMBus/I ² C 2-Byte Read Timing Diagram	10	Table 6. Alert Fault Queue setup.....	15
Figure 7. Shutdown Current vs Vcc.....	11	Table 7. Conversion ratio setup.....	16
Figure 8. Average Current vs Vcc.....	11	Table 8. Slave address vs. AD0 pin connection.....	18
Figure 9. Temperature Error vs. Ambient Temperature.....	11		
Figure 10. Humidity Error vs Ambient Humidity	11		
Figure 11. Humidity Error vs Vcc(T=25°C)	11		
Figure 12. Temperature Error vs. Vcc(RH=50%)	11		
Figure 13. ALERT pin output in interrupt mode	17		
Figure 14. ALERT pin output in comparator mode	17		
Figure 15. Sensor typical application	20		
Figure 16. Sensor placement example at PCB	21		
Figure 17. Sensor PCB layout example	21		

Low Voltage Digital Humidity and Temperature Sensor

Description

CHT8310 is a low voltage digital humidity and temperature sensor with $\pm 2\%RH$ (Typ.) accuracy for humidity and $\pm 0.2^{\circ}C$ (Typ.) accuracy for temperature. Humidity and Temperature data can be read out directly via digital interface by MCU, Bluetooth Chip or SoC chip.

The digital interface is compatible with SMBus and I²C protocol. Also it supports communication with fast speed (up to 400kHz) and high speed (up to 1.0MHz) for I²C protocol.

Each chip is specially calibrated for temperature and humidity accuracy in factory before shipment to customers. There is no need for re-calibration anymore.

It includes a high precision band-gap circuit, an analog to digital converter, a calibration unit with non-volatile memory, and a digital interface block.

It has ALERT logic output pin with open drain structure, which is active low or high.

The chip supports up to 4 devices in one I²C bus by setting different slave address via AD0 pin.

Available Package: DFN3x3-6 package

Features

- Operation Voltage: 1.65V to 5.5V
- Average Operating Current: 2.0uA (Typ.)@ 3.3V, 1Con/s for Both temperature and humidity Conversion
- Standby Current: 55nA(Typ.)
- Temperature Accuracy with calibration:
 - $\pm 0.2^{\circ}C$ (Typ.) from $0^{\circ}C$ to $80^{\circ}C$
 - $\pm 0.4^{\circ}C$ (Typ.) from $-20^{\circ}C$ to $100^{\circ}C$
 - $\pm 0.5^{\circ}C$ (Typ.) from $-40^{\circ}C$ to $125^{\circ}C$
- Humidity Accuracy with calibration: $\pm 2\%RH$ (Typ.) from 20%RH to 80%RH
- Digital Interface compatible with SMBus and I²C, support:
 - Up to 4 different slave addresses by setting AD0 pin
 - Packet Error Checking feature to improve communication reliability and robustness
 - Speed up to 1.0MHz
 - SMBus timeout feature
 - SMBus Alert Response Alert (ARA)
 - SMBus General Call
- Programmable High/Low Limit Alert for Temperature and/or Humidity
- Supports One shot or continuous measurement
- Temperature Range: $-40^{\circ}C$ to $125^{\circ}C$
- Humidity Range: 0%RH to 100%RH

Applications

- Smart HVAC System
- Environment Monitor
- Portable/Wearable Weather Monitor

PIN Configurations (Top View)

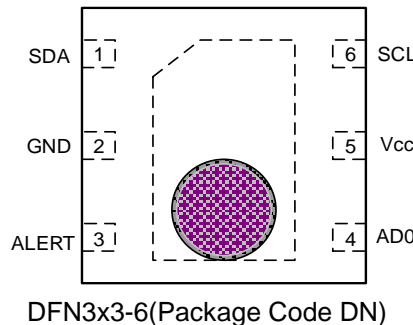

Typical Application

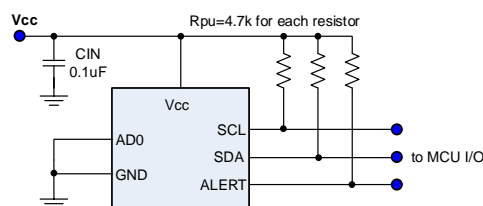

Figure 1. Typical Application of CHT8310

Pin Description

PIN No.	PIN Name	Description
1	SDA	Digital interface data input or output pin, need a pull-up resistor to Vcc.
2	GND	Ground pin.
3	ALERT	To Indicate alert status of over Humidity and/or Temperature limitation programmed by setting temperature and/or high/low-limit registers. Need a pull-up resistor to Vcc in application. It is open drain output with active low or high by setting POL bit.
4	AD0	Slave Address selection pin, the chip can be defined total 4 different slave addresses by connecting this pin to GND, Vcc, SCL or SDA pin respectively. If leave this pin open, address is 0x80. See Slave Address for detail.
5	Vcc	Power supply input pin, using 0.1uF low ESR ceramic capacitor to ground
6	SCL	Digital interface clock input pin, need a pull-up resistor to Vcc.
	Thermal Pad	Not connected with any internal pin

Function Block

Figure 2. CHT8310 function block

Low Voltage Digital Humidity and Temperature Sensor
Ordering Information

Order PN	Accuracy	Green ¹	Package	Marking ID ²	Packing	MPQ	Operation Temperature	Protection Cover
CHT8310DNR	±0.2°C ±2.0%RH	Halogen free	DFN3x3-6	8310 YWWAXX	Tape & Reel	3,000	-40°C~+125°C	No
CHT8310DNR-C	±0.2°C ±2.0%RH	Halogen free	DFN3x3-6	8310 YWWAXX	Tape & Reel	3,000	-40°C~+125°C	Yes

Notes

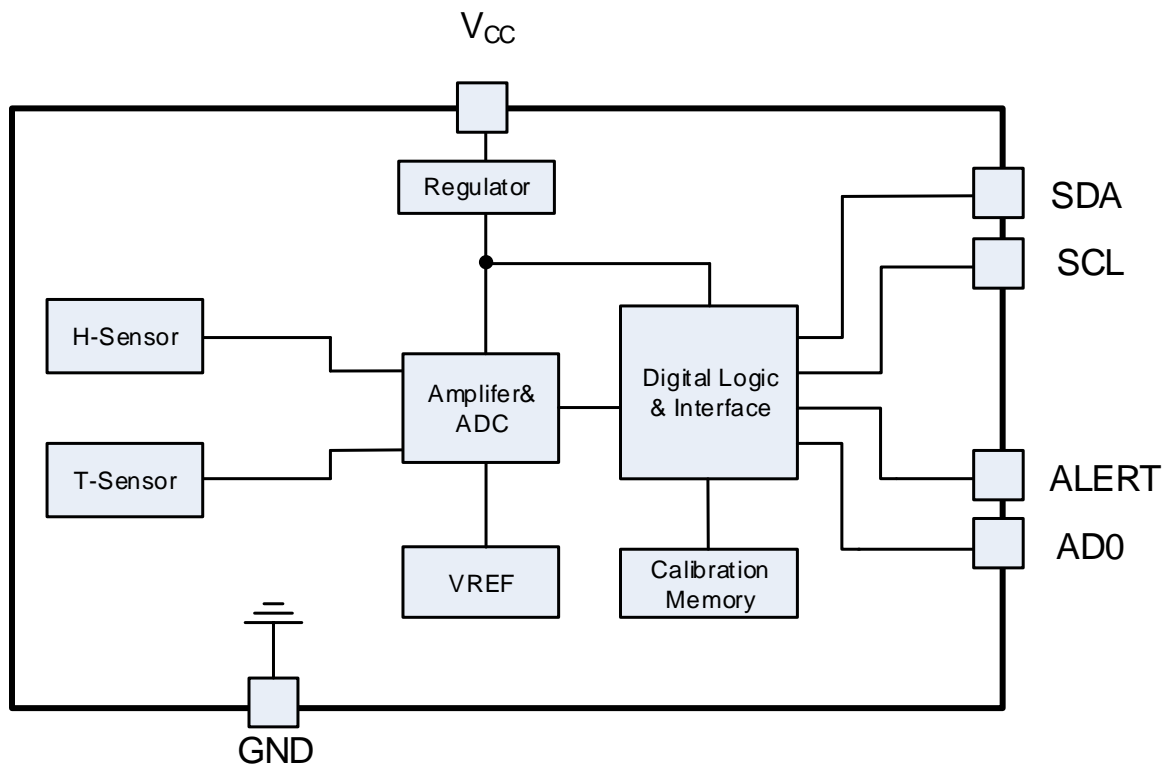
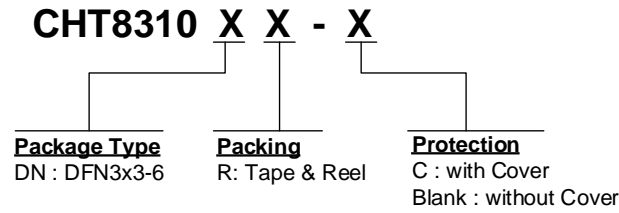
1. Sensylink can meet RoHS 2.0/REACH requirement. So most package types Sensylink offers only states halogen free, instead of lead free.
2. Marking ID includes 2 rows of characters. In general, the 1st row of characters are part number, and the 2nd row of characters are date code plus production information.

Low Voltage Digital Humidity and Temperature Sensor

Absolute Maximum Ratings (Note1)

Parameter	Symbol	Value	Unit
Supply Voltage	V_{CC} to GND	-0.3 to 7	V
SDA, SCL, AD0 Voltage	$V_{SDA}/V_{SCL}/V_{AD0}$ to GND	-0.3 to 7	V
ALERT Voltage	V_{ALERT} to GND	-0.3 to 7	V
Junction temperature	T_{JMAX}	150	°C
Storage temperature Range	T_{STG}	-65 to 150	°C
Lead Temperature (Soldering, 10 Seconds)	T_{LEAD}	260	°C
ESD HBM	ESD_{HBM}	±4000	V
ESD CDM	ESD_{CDM}	±1000	V

Note1

- Stresses greater than those listed under "Absolute Maximum Ratings" may cause permanent damage to the device. These are stress ratings only. Functional operation of the device at the "Absolute Maximum Ratings" conditions or any other conditions beyond those indicated under "Recommended Operating Conditions" is not recommended. Exposure to "Absolute Maximum Ratings" for extended periods may affect device reliability.

Recommended Operating Conditions

Parameter	Symbol	Value	Unit
Supply Voltage	V_{CC}	1.65~ 5.5	V
Ambient Operation Temperature Range	T_{AT}	-40~+125	°C
Ambient Operation Temperature Range for Humidity measurement	T_{ATH}	0~ +80	°C
Ambient Operation Humidity Range	T_{AH}	0~100	%RH

Low Voltage Digital Humidity and Temperature Sensor

Electrical Characteristics (Note2)

Test Conditions: CIN = 0.1uF, Vcc = 3.3V, TA=25°C unless otherwise specified.

Parameter	Symbol	Test Conditions	Min	Typ	Max	Unit
Supply Voltage	VCC		1.65		5.5	V
Average Operating Current	IAOC	Average @ 1 measurement every 125 millisecond RH + temperature		8.5	12.0	uA
		Average @ 1 measurement every 1 second RH + temperature		2.0	2.5	uA
		Average @ 1 measurement every 10 seconds RH + temperature		0.25	0.45	uA
		Average @ 1 measurement every 120 seconds RH + temperature		60	125	nA
Shutdown Current	ISHUTDOWN	Standby mode, no iteration on SDA/SCL		55	105	nA
Open Drain Output Voltage	VOL	ALERT pin, sink 5mA	0		0.4	V
Open Drain Leakage	IODL	ALERT pin	-1.0		1.0	uA
Heater Current	IHEATER	Peak Current during Heater Enable		5		mA
Temperature Range			-40		125	°C
Temperature Accuracy	TAC	TA = 0 to 80°C		±0.2	±0.3	°C
		TA = -20 to 100°C		±0.4	±0.8	°C
		TA = -40 to 125°C		±0.5	±1.0	°C
Temperature Resolution			0.03125			°C
Humidity Range			0		100	%RH
Humidity Accuracy	HAC	HA = 50%RH		±1.5	±3.5	%RH
		HA = 20%RH to 80%RH		±2	±3.5	%RH
		HA = 5%RH to 95%RH		±3	±5	%RH
Humidity Resolution			0.02			%RH
Humidity Hysteresis	HHYS			±1.0		%RH
Humidity Response time	t63%			8		s
Conversion time	tCON	Both 1 Humidity and 1 Temperature measurement		11		ms
Conversion Current	ICON	Both 1 Humidity and 1 Temperature measurement		90		uA
Digital Interface						
Logic Input Capacitance	CIL	SDA, SCL pin		3.0		pF
Logic Input High Voltage	VIH	SDA, SCL pin	0.7*Vcc		Vcc+0.3	V
Logic Input Low Voltage	VIL	SDA, SCL pin	-0.3		0.3*Vcc	V
Logic Input Current	IINL	SDA, SCL pin	-1.0		1.0	uA
Logic Output Sink Current	IOLS	SDA, SCL pin, forced 0.2V		4.0		mA
SCL frequency	fCLK	Fast Mode	1		400	kHz
		High Speed Mode	0.001		1.0	MHz
Timeout of detecting clock low period time	tTOUT	SMBus Communication		25		ms
Clock low period time	tLOW	Fast Mode	1300			ns
Clock high period time	tHIGH	Fast Mode	600			ns
Bus free time	tBUF	Between Stop and Start condition	1200			ns
Hold time after Start condition	tHD:STA		600			ns
Repeated Start condition setup time	tSU:STA		600			ns
Stop condition setup time	tSU:STO		600			ns
Data Hold time	tHD:DAT		0			ns
Data Setup time	tSU:DAT		100			ns
Clock/Data fall time	tF				300	ns
Clock/Data rise time	tSR				1000	ns

Note 2:

1. All devices are 100% production tested at TA = +25°C; All specifications over the automotive temperature range is guaranteed by design, not production tested.
2. Time for the RH output to change by 63% of the total RH change after a step change in environmental humidity.
3. For humidity accuracy, it excludes hysteresis, high temperature baker, hydration drift, long-term drift.

Low Voltage Digital Humidity and Temperature Sensor

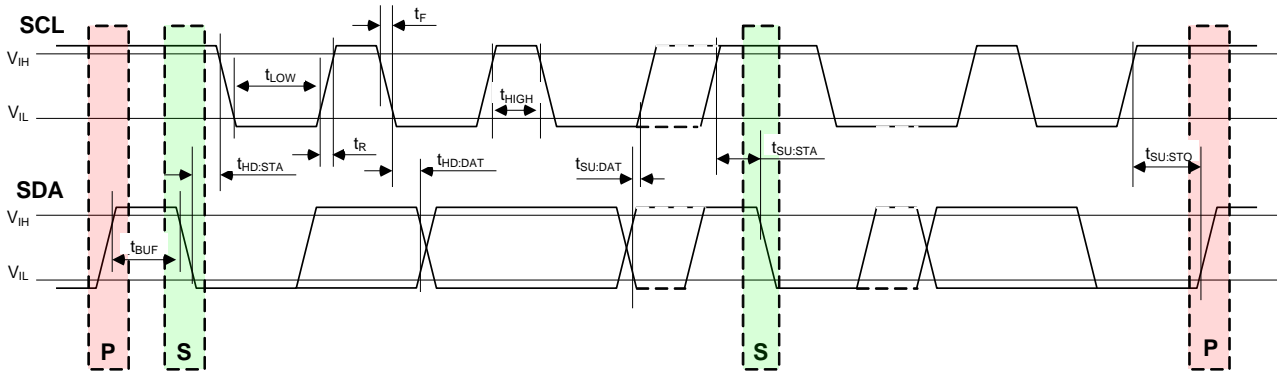

Figure 3. I²C Timing Diagram

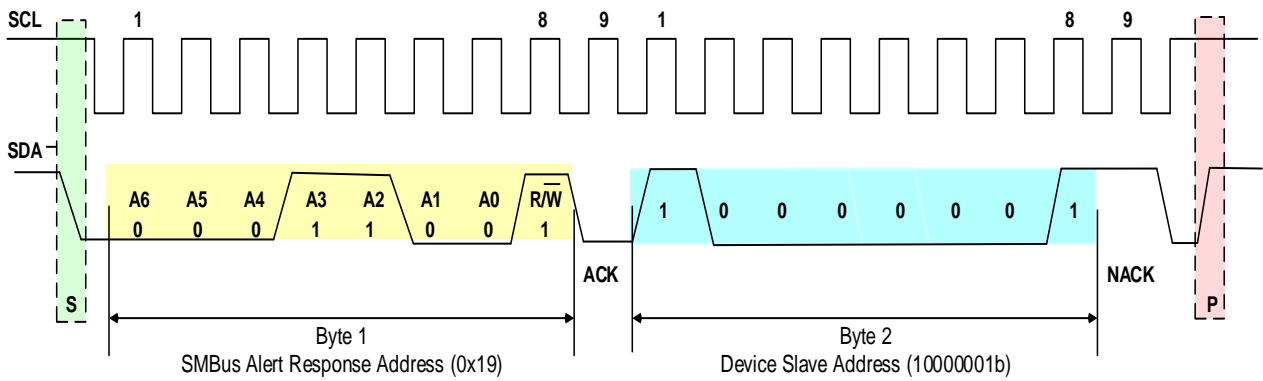

Figure 4. SMBus ALERT Response Diagram

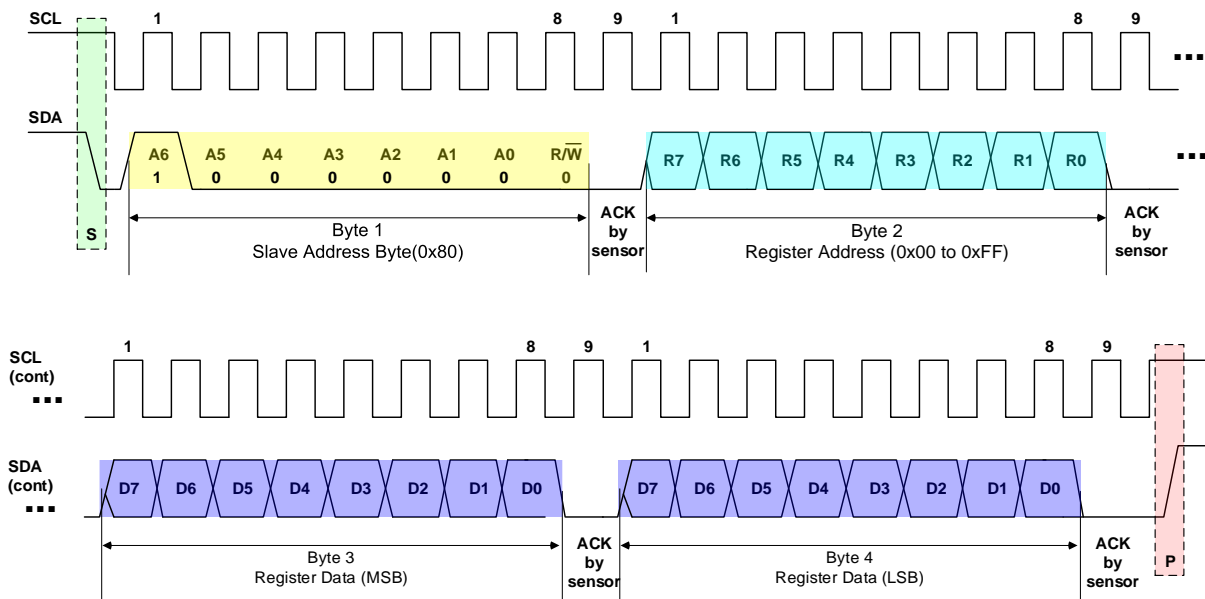

Figure 5. SMBus/I²C 2-Byte Write Timing Diagram

Low Voltage Digital Humidity and Temperature Sensor

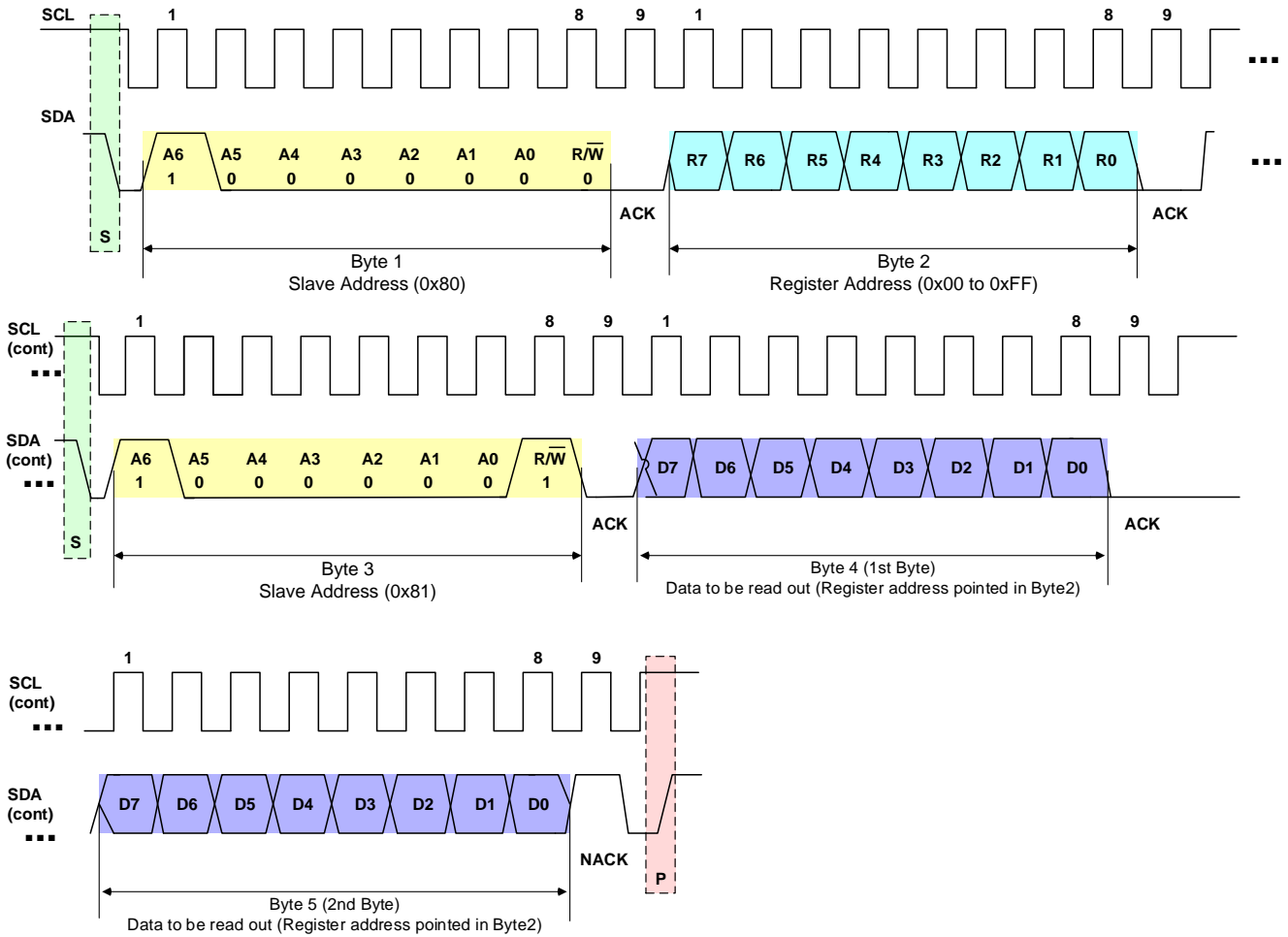

Figure 6. SMBus/I²C 2-Byte Read Timing Diagram

Low Voltage Digital Humidity and Temperature Sensor

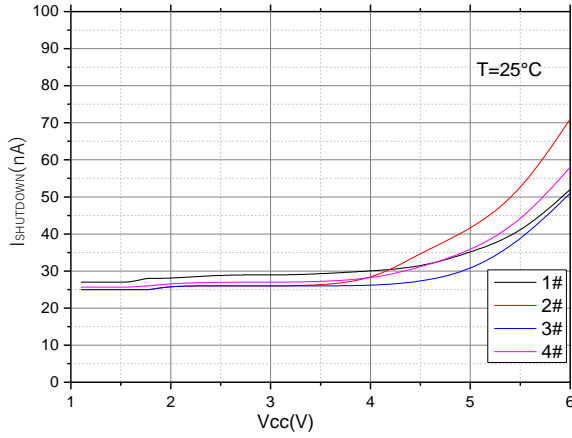

Figure 7. Shutdown Current vs Vcc

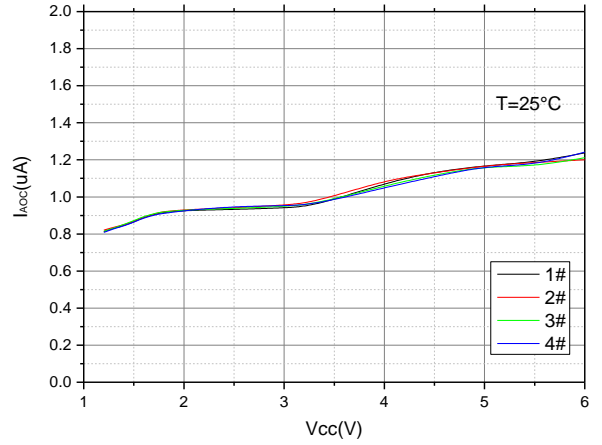

Figure 8. Average Current vs Vcc

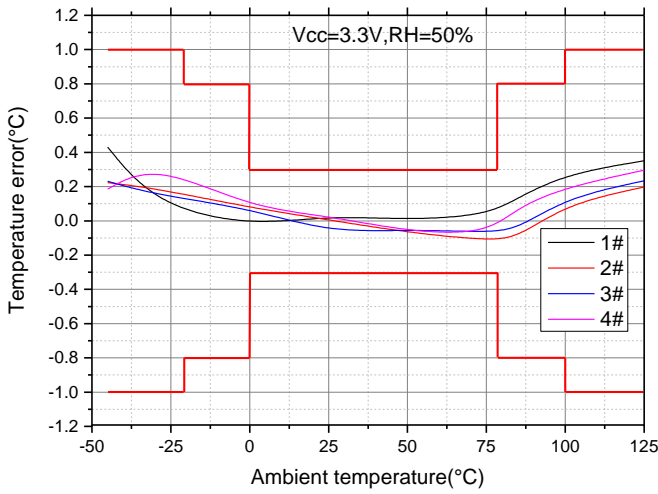

Figure 9. Temperature Error vs. Ambient Temperature

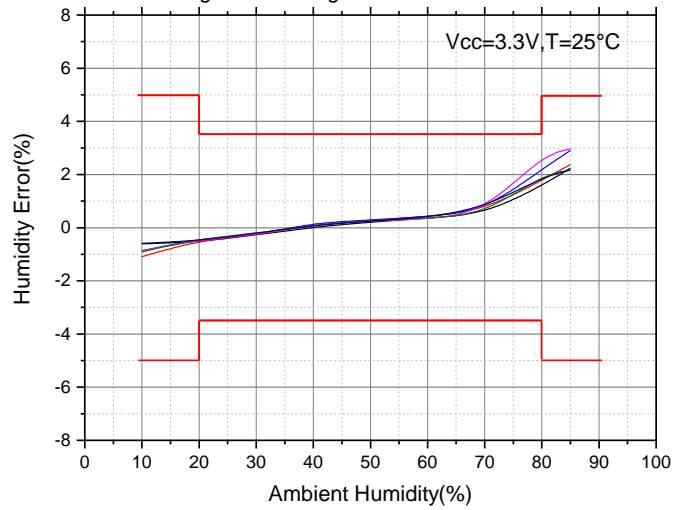

Figure 10. Humidity Error vs Ambient Humidity

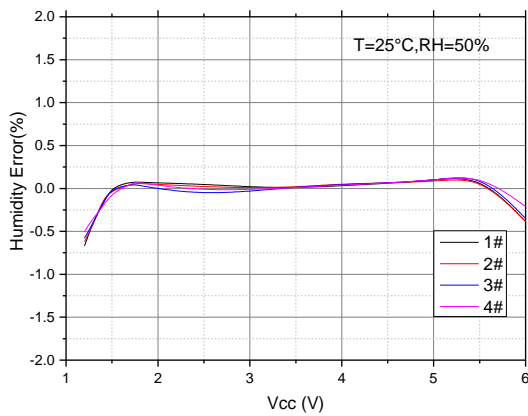

Figure 11. Humidity Error vs Vcc(T=25°C)

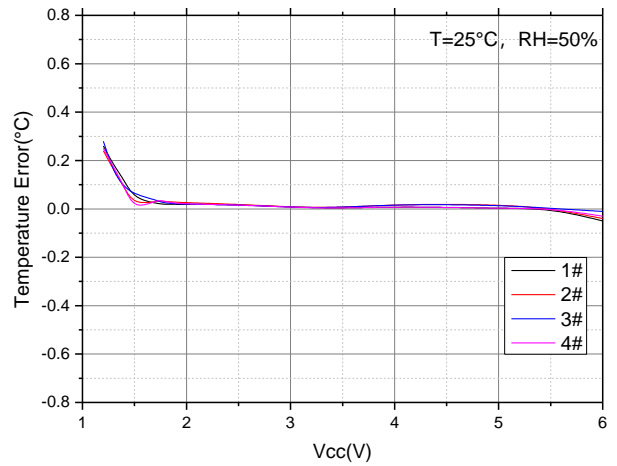

Figure 12. Temperature Error vs. Vcc(RH=50%)

Low Voltage Digital Humidity and Temperature Sensor

1 Function Descriptions

The chip can sense both temperature and humidity that integrates temperature and humidity sensor transducers, an analog-to-digital converter, signal processing, calibration and SMBus/I2C interface in a single chip. The chip is individually calibrated for both temperature and humidity before shipment using on-chip non-volatile memory. It is permitted to connect 4 sensors with different slave addresses at the same bus by setting AD0 PIN. Also the chip supports programmable high/low-limit of temperature and humidity settings. If the measured temperature and/or humidity exceed the high/low-limit threshold, ALERT pin will be asserted. Alert is active low in default, or active high once setting POL bit as '1'.

1.1 Register map (Note3)

The sensor has 12 registers that user can access. The detail information is shown as below.

Table 1. Register Maps Definition

Register Address	Register Name	Attribution	M/L	Default Data	BIT							
					7	6	5	4	3	2	1	0
0x00	Temperature	RO	MSB	0	LT[14]	LT[13]	LT[12]	LT[11]	LT[10]	LT[9]	LT[8]	LT[7]
			LSB	0	LT[6]	LT[5]	LT[4]	LT[3]	LT[2]	LT[1]	LT[0]	
0x01	Humidity	RO	MSB	0	OL	HD[14]	HD[13]	HD[12]	HD[11]	HD[10]	HD[9]	HD[8]
			LSB	0	HD[7]	HD[6]	HD[5]	HD[4]	HD[3]	HD[2]	HD[1]	HD[0]
0x02	Status	RO	MSB	0	Busy	THIGH	TLOW	HHhigh	HLow			
			LSB	0								
0x03	Configure	RW	MSB	8	Mask	SD	ALTH	EM	x	x	x	EHT
			LSB	80	TME	0	POL	ALT_SRC[1:0]		CONSEC_FQ[1:0]		ATM
0x04	Convert rate	RW	MSB	4						CR[2]	CR[1]	CR[0]
			LSB	0								
0x05	Temperature high limit	RW	MSB	55	TH[14]	TH[13]	TH[12]	TH[11]	TH[10]	TH[9]	TH[8]	TH[7]
			LSB	0	TH[6]	TH[5]	TH[4]	TH[3]	TH[2]	TH[1]	TH[0]	
0x06	Temperature low limit	RW	MSB	D8	TL[14]	TL[13]	TL[12]	TL[11]	TL[10]	TL[9]	TL[8]	TL[7]
			LSB	0	TL[6]	TL[5]	TL[4]	TL[3]	TL[2]	TL[1]	TL[0]	
0x07	Humidity high limit	RW	MSB	D9	0	HH[14]	HH[13]	HH[12]	HH[11]	HH[10]	HH[9]	HH[8]
			LSB	0								
0x08	Humidity low limit	RW	MSB	0	0	HL[14]	HL[13]	HL[12]	HL[11]	HL[10]	HL[9]	HL[8]
			LSB	0								
0x0F	Oneshot	W/O	MSB		x	x	x	x	x	x	x	x
			LSB		x	x	x	x	x	x	x	x
0xFC	SWRST	W/O	MSB	FF	x	x	x	x	x	x	x	x
			LSB	FF	x	x	x	x	x	x	x	x
0xFE	Manufacture ID	RO	MSB	59	0	1	0	1	1	0	0	1
			LSB	59	0	1	0	1	1	0	0	1

Note 3: R/W -- means Readable/Writable; R/O -- means read only; W/O -- means write only; X -- Means do not care whatever '0' or '1'; RSV -- means Reserved.

1.1.1 Temperature Measurement Data

The temperature measurement data is stored in read only temperature register. The temperature register is in 13-bit binary format (set EM bit as '0') or 14-bit binary format (set EM bit as '1') This can make sure the

Low Voltage Digital Humidity and Temperature Sensor

MSB and LSB data are from the same conversion. The relationship between temperature data in Celsius degree and binary data is shown as below tables. When EM bit is set as '0' in default, the temperature resolution is 0.03125°C with the expression range of -128°C to 128°C. When EM bit is set as '1', the temperature resolution is still 0.03125°C with the expression range of -256°C to 256°C.

Table 2. 13-bit Temperature Data (EM bit = 0)

Temperature (°C)	13-bit Digital Output (HEX)	13-bit Digital Output (BIN)
+128.000	0x7FF8	0 1 1 1, 1 1 1 1, 1 1 1 1, 1 (0 0 0)
+127.96875	0x7FF8	0 1 1 1, 1 1 1 1, 1 1 1 1, 1 (0 0 0)
+127.9375	0x7FF0	0 1 1 1, 1 1 1 1, 1 1 1 1, 0 (0 0 0)
+100.000	0x6400	0 1 1 0, 0 1 0 0, 0 0 0 0, 0 (0 0 0)
+25.000	0x1900	0 0 0 1, 1 0 0 1, 0 0 0 0, 0 (0 0 0)
+0.250	0x0040	0 0 0 0, 0 0 0 0, 0 1 0 0, 0 (0 0 0)
+0.03125	0x0008	0 0 0 0, 0 0 0 0, 0 0 0 0, 1 (0 0 0)
0.000	0x0000	0 0 0 0, 0 0 0 0, 0 0 0 0, 0 (0 0 0)
-0.03125	0xFFF8	1 1 1 1, 1 1 1 1, 1 1 1 1, 1 (0 0 0)
-0.250	0xFFC0	1 1 1 1, 1 1 1 1, 1 1 0 0, 0 (0 0 0)
-25.000	0xE700	1 1 1 0, 0 1 1 1, 0 0 0 0, 0 (0 0 0)

$$\text{Temp (}^\circ\text{C)} = (\text{Temperature [12:0]}_{\text{complement}} \gg 3) * 0.03125 \quad [\text{EM}=0]$$

Table 3. 14-bit Temperature Data (EM bit = 1)

Temperature (°C)	14-bit Digital Output (HEX)	8-bit Digital Output (BIN) (MSB Byte)	8-bit Digital Output (BIN) (LSB Byte)
+150.000	0x4B00	0 1 0 0, 1 0 1 1	0 0 0 0, 0 0 0 0
+128.000	0x4000	0 1 0 0, 0 0 0 0	0 0 0 0, 0 0 0 0
+127.96875	0x3FFC	0 0 1 1, 1 1 1 1	1 1 1 1, 1 1 0 0
+127.9375	0x3FF8	0 0 1 1, 1 1 1 1	1 1 1 1, 1 0 0 0
+100.000	0x3200	0 0 1 1, 0 0 1 0	0 0 0 0, 0 0 0 0
+25.000	0x0C80	0 0 0 0, 1 1 0 0	1 0 0 0, 0 0 0 0
+0.250	0x0020	0 0 0 0, 0 0 0 0	0 0 1 0, 0 0 0 0
+0.03125	0x0002	0 0 0 0, 0 0 0 0	0 0 0 0, 0 1 0 0
0.000	0x0000	0 0 0 0, 0 0 0 0	0 0 0 0, 0 0 0 0
-0.03125	0xFFFF	1 1 1 1, 1 1 1 1	1 1 1 1, 1 0 0 0
-0.250	0xFFE0	1 1 1 1, 1 1 1 1	1 1 1 0, 0 0 0 0
-25.000	0xF380	1 1 1 1, 0 0 1 1	1 0 0 0, 0 0 0 0

$$\text{Temp (}^\circ\text{C)} = (\text{Temperature [13:0]}_{\text{complement}} \gg 2) * 0.03125 \quad [\text{EM}=1]$$

Table 4 Temperature Data Register

BIT	MSB (1st Byte)								LSB (2nd Byte)							
	7	6	5	4	3	2	1	0	7	6	5	4	3	2	1	0
EM=0	S	2 ⁶	2 ⁵	2 ⁴	2 ³	2 ²	2 ¹	2 ⁰	2 ⁻¹	2 ⁻²	2 ⁻³	2 ⁻⁴	2 ⁻⁵	0	0	0
	SIGN	64	32	16	8	4	2	1	0.5	0.25	0.125	0.0625	0.03125	0	0	0
EM=1	S	2 ⁷	2 ⁶	2 ⁵	2 ⁴	2 ³	2 ²	2 ¹	2 ⁰	2 ⁻¹	2 ⁻²	2 ⁻³	2 ⁻⁴	2 ⁻⁵	0	0
	SIGN	128	64	32	16	8	4	2	1	0.5	0.25	0.125	0.0625	0.03125	0	0

Low Voltage Digital Humidity and Temperature Sensor

1.1.2 Relative Humidity Measurement Data

The relative humidity measurement data is stored in read only humidity register. The humidity register is in 16-bit binary format with address 0x01. The highest bit of humidity register is OL. When the humidity value reaches the upper limit of 100%, OL bit will be set to '1'. The relationship between humidity data in %RH unit and binary data is shown as below formula. Also humidity data can be considered as combination by each bit with 0.003%RH resolution, shown as below table.

Table 4. 16-bit humidity data

Humidity (%RH)	16-bit Digital (DEC)	16-bit Digital (HEX)	8-bit Digital (BIN) [MSB]	8-bit Digital (BIN) [LSB]
100	-	-	1 x x x, x x x x	x x x x, x x x x
52	17039	0x428F	0 1 0 0, 0 0 1 0	1 0 0 0, 1 1 1 1
21	6881	0x1AE1	0 0 0 1, 1 0 1 0	1 1 1 0, 0 0 0 1
0	0	0x0000	0 0 0 0, 0 0 0 0	0 0 0 0, 0 0 0 0

$$\text{Relative Humidity (\%RH)} = 100\% * \frac{\text{Humidity}[\text{bit14:0}]}{2^{15}}$$

1.1.3 Config Registers

Config register address is 0x03, The definition and function for each bit are explained as below.

Mask, ALERT trigger mask bit

This bit allows user to mask ALERT trigger event.

Set this bit as '1', means mask or disable ALERT trigger event caused by measured temperature or humidity exceeds high/low-limit register value. The default is 0, means to enable ALERT trigger.

SD, standby mode bit

This bit allows user to shutdown the chip and to make the chip enter into standby mode once writing '1'. The default value is '0', which sets the chip in normal working mode. During standby mode, the temperature data is kept at that of last time, no anymore update, and all function blocks are turned-off except interface. In standby mode, user can do one time measurement for temperature and humidity by writing any data (0x0000 to 0xFFFF) into one-shot register (register address, 0x0F). The quiescent is 50nA (Typ.) in shutdown mode.

ALTH, Hysteresis comparison mode

This bit allows user to select Hysteresis comparison mode. Set this bit as '1', When the temperature /humidity exceeds the upper limit, alert active, Only when the temperature/humidity is equal or lower than the lower limit, Alert status can be released. Set this bit as '0', When the temperature/humidity exceeds the upper limit, or lower than the lower limit, alert active.

EM, Extended Mode bit

This bit allows user to select 13-bit (EM = 0) or 14-bit (EM = 1) temperature data format. In default, the EM bit is '0', the temperature data is 13-bit format. And the expression range is from -128°C to 128°C in this format. When measured temperature exceeds 128°C, user can set EM bit as '1', the temperature data is 14-bit format, and there solution is still 0.03125°C. The expression range is extended from -255°C to +255°C.

Low Voltage Digital Humidity and Temperature Sensor

EHT, heater bit

This bit allows user to set the heater built in the chip on/off, which can prevent condensation in the cavity of package. Set this bit as '1', will set the heater on. When the heater is on, the current of heater is about 5.0mA at 3.3V, which will cause temperature higher 15°C than ambient if the sensor is in the socket. The default is 0, will set the heater off.

TME, clock timeout for SMBus

This bit allows user to setup timeout feature for SMBus protocol. Setting this bit as '1' will enable timeout feature. If the clock (SCL PIN) or data (SDA pin) is held low for longer than 25 ms (Typ.), the chip will reset its SMBus protocol and be ready for a new transmission when timeout feature is enabled. After POR, TME bit is 1, which means timeout feature is enabled in default. It is better to keep clock frequency no lower than 1 kHz to avoid triggering timeout feature. Set this bit as 0, will disable timeout feature.

POL, Alert Output Polarity bit

This bit allows user to setup the polarity of ALERT pin for output. The default is 0 after POR, meaning ALERT pin is active low. When POL bit is set as '1', the ALERT pin becomes active high and the state of ALERT pin is inverted.

ALT_SRC1, ALT_SRC0, alert trigger source setup bits

These 2 bits allow user to select temperature and/or humidity violates high/low limits. After POR, the default is 00, which means if temperature or humidity measured data violates high/low limits, alert will be triggered. Violation high/low limits, means measured data exceeds high-limit setup or drops below low limit setup. If setting these 2 bits as 11, which means only if both temperature and humidity violate high/low limit happens can trig alert.

Table 5. Alert trigger source setup

ALT_SRC[1:0]	Trigger source
00 (default)	Temperature or humidity
01	Temperature only
10	Humidity only
11	Both temperature and humidity

CONSEC_FQ[1:0], Fault Queue bits

These 2 bits are used to setup the number of fault conditions to trigger alert. The default is 00 after POR, which means one time fault. This feature is used to prevent a false alert, which is immune to certain noise in application.

Table 6. Alert Fault Queue setup

CONSEC_FQ[1:0]	Fault Queue Number
00	1 (default)
01	2
10	4
11	6

ATM, Alert Operation Mode bit

This bit allows user to select ALERT trigger operation mode: Interrupt Mode or Comparator Mode. The default is 0 after POR to select Interrupt Mode. For detail information, see ALERT output section.

Low Voltage Digital Humidity and Temperature Sensor

1.1.4 Conversion Setup Register

The chip supports multiple selections for conversion ratio by setting CR [2:0] bits. After POR, these 3 bits are 100, which means the chip does temperature and humidity measurement one time per second.

Table 7. Conversion ratio setup

CR[2:0]	time per measurement of T + H	Measurement Frequency
000	120s	1/120 Hz
001	60s	1/60 Hz
010	10s	1/10 Hz
011	5s	1/5 Hz
100(default)	1s	1 Hz
101	500ms	2 Hz
110	250ms	4 Hz
111	125ms	8Hz

1.1.5 High/Low-limit Alert Setup for temperature and humidity

The chip has 4 kinds of limit registers, including temperature high-limit, temperature low-limit, humidity high-limit, humidity low-limit, which can be setup and stored for temperature high/low-limit and humidity high/low-limit threshold value.

1.1.6 One-shot Register

When the sensor is in standby mode (SD bit is '1'), writing any data (from 0x0000 to 0xFFFF) into one-shot register (register address is 0x0F) will trigger a single time temperature and humidity measurement. The sensor returns to standby mode again once it completes the single measurement. This feature is used for reducing power consumption when continuous temperature monitoring is not necessary.

1.1.7 Manufacture ID

Manufacture ID is the ready only register, for this sensor, the data is 0x5959.

1.2 ALERT Output

The sensor has ALERT out pin, and alert will be asserted when temperature and/or humidity violate high/low-limit setup. There are related setups shown as blow which will affect ALERT.

ALERT source, ALT_SRC[1:0]

Once any of below conditions happens, alert will be triggered assuming ALT_SRC[1:0] is 00 as default:

- 1) measured temperature data exceeds temperature high-limit register value;
- 2) measured temperature is equal or below temperature low-limit register value;
- 3) measured humidity data exceeds humidity high-limit register value;
- 4) measured humidity data is equal or below humidity low-limit register value;

If ALT_SRC[1:0] is set as other value, could be response for temperature only, or humidity only, see config register section for detail.

CONSEC_FQ [1:0]

This two register bits are used to set violation numbers when trigger condition happens. The default is one time.

ALERT output polarity, POL

The default is active low when alert trigger happens.

Low Voltage Digital Humidity and Temperature Sensor

ALERT Mode, ATM

There are two types of ALERT output mode: interrupt mode and comparator mode depending on ATM bit. The default is interrupt mode.

1.2.1 Interrupt mode (ATM = 0)

Below Figure shows the mechanism of the ALERT output in interrupt mode. In this mode, the ALERT pin will become active if the monitored temperature and/or humidity violate the value setup in high/low-limit registers for a consecutive number of faults according to setup by F1 and F0 bits. The ALERT pin keeps active until a read operation of status register happens or the chip responds to SMBus Alert Response Address (ARA) successfully.

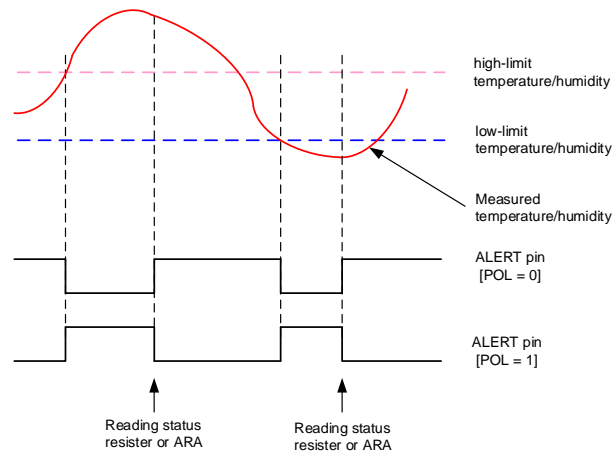

Figure 13. ALERT pin output in interrupt mode

In this mode, ALERT pin is released only after reading operation for status register or SMBus ARA response successfully no matter with measured temperature/humidity are kept between high-limit and low-limit.

1.2.2 Comparator mode (ATM = 1)

Below Figure shows the mechanism of the ALERT output in comparator mode. In this mode, the ALERT pin will become active if the monitored temperature and/or humidity violate the value setup in high/low-limit registers for a consecutive number of faults according to setup by F1 and F0 bits. The ALERT pin keeps active until the temperature falls between high-limit and low-limit register value.

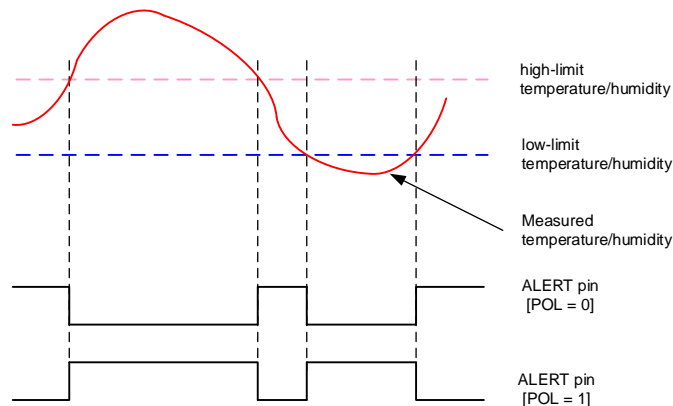

Figure 14. ALERT pin output in comparator mode

Low Voltage Digital Humidity and Temperature Sensor

It is necessary to use external pull-up 4.7k to 10k resistor for ALERT pin in application whatever active low or high. ALERT pin trigger happens only after each measurement cycle. In each measurement cycle, the chip will compare data of temperature and humidity register to that of high/low-limit threshold register. Compare result will be performed at both ALERT pin and related bit of status register (bit14 to bit11).

No matter with comparator mode or interrupt mode, bit14 to bit11 status only depends on measured temperature/humidity data versus high/low-limit threshold value.

- 1) measured temperature > temperature high-limit register, bit6 (THA) will be set as 1;
- 2) measured temperature \leq temperature low-limit register, bit5 (TLA) will be set as 1;
- 3) measured humidity > humidity high-limit register, bit4 (HHA) will be set as 1;
- 4) measured humidity \leq humidity low-limit register, bit3 (HLA) will be set as 1;

1.3 Do Measurement Procedure

The sensor can be easily used to read out temperature and humidity data.

1.3.1 Step 1, setup the sensor working mode via Config, Conv_Rate registers

User can change config registers (Config 1 and Config 2), to setup expected working mode. Of course it is ok to use the default setup, just ignore this step. In default setup, the sensor will do temperature and humidity conversion and update the T and H register using new measurement data in every second.

1.3.2 Step 2, read out temperature and/or humidity measurement data

Once conversion is finished, temperature and humidity raw data can be obtained by reading register 0x00, 0x01 respectively via I²C bus.

1.4 Digital Interface

1.4.1 Slave Address

The chip is compatible with industry standard I²C protocol as slave device communication with host via SDA and SCL pin. Both SDA and SCL pin are open drain structure, so it is necessary to use 2 pull-up resistors of 4.7k to 10k. The communication speed supports up to 400 kHz. The I²C slave address of this device can be configured 4 different addresses by setting AD0 pin. See below table for detail. This permits connecting total 4 devices in one same bus. If keeping AD0 pin float is the same as connecting AD0 pin to GND.

Table 8. Slave address vs. AD0 pin connection

No.	AD0	R/W bit	Slave Address in Hex[R/W]
1	GND	1/0	0x81/0x80
2	Vcc	1/0	0x89/0x88
3	SDA	1/0	0x91/0x90
4	SCL	1/0	0x99/0x98

1.4.2 Timeout

The chip supports SMBus timeout. If the data (SDA PIN) or clock (SCL PIN) is held low for longer than 25ms (Typ.), the chip will reset its SMBus protocol and be ready for a new transmission when timeout feature is enabled. After POR, SMBTO bit (bit7 of Config 2 register) is 1, which means timeout feature is enabled in default. It is better to keep clock frequency no lower than 1 kHz to avoid triggering timeout feature.

1.4.3 SMBus Alert Response Address (ARA)

The chip supports the SMBus alert function. The ALERT pin of the chip can be connected as SMBus alert signal, used as a processor interrupt. When the master detects that the ALERT pin is active, it can send

Low Voltage Digital Humidity and Temperature Sensor

Alert Response Address (ARA) command (0001, 1001b) on the bus. Then the chip will acknowledge the ARA command by returning the slave address from SDA line.

Here Reg Address presented the chip real actual address setup by user.

1.4.4 General Call

The chip supports reset via General Call Address (0000 0000) on the bus. The chip acknowledges the general-call address and responds to commands in the second byte. If the second byte is 0000 0110, the chip all internal registers are reset to default values.

1.4.5 High Speed Mode

If user wants to run I²C/SMBus at frequency above 400 kHz, the master device must issue an Hs-mode master code (0000 1xxx) as the first byte after a START condition to switch the bus into high-speed operation. After the Hs-mode master code has been issued, the master transmits a slave address to initiate a data-transfer operation. The bus continues to operate in Hs-mode until a STOP condition occurs on the bus. Upon receiving the STOP condition, the chip will return back to fast mode operation. In high speed mode, the chip supports clock frequency up to 1.0MHz. Below is the example for writing config register operation with high speed mode.

S	Hs mode code	ACK	Slave Address	R/W	ACK	Reg Address	ACK	Data	ACK	P
	0000,1xxx	1	xxx1,1xx (configured by user)	0	0	0x02	0	0x80	1	

1.4.6 PEC

The chip supports another useful feature of SMBus, Packet Error Checking which can improve communication reliability and robustness. Packet Error Checking is implemented by appending a Packet Error Code (PEC) at the end of each message transfer. Each protocol has two variants: one with the Packet Error Code (PEC) byte and one without. The PEC is a CRC-8 error-checking byte with below polynomial, calculated on all the message bytes (including addresses and read/write bits). The PEC is appended to the message the last data byte.

$$C(x) = X^8 + X^2 + X^1 + 1$$

For this chip, the PEC function is enabled by default. For example, a 2-byte read transaction starts with the START (S) condition (generated by the master device), and then sends the slave address of the chip, followed by the R/W bit "0". The chip is confirmed with the ACK (A) bit, and the host sends the register address (for example, 0x00), followed by another ACK from the chip. The host sends a restart signal, and then sends the slave address of the chip, followed by the R/W bit "1". The chip confirms with another ACK (A) bit, and then outputs 2-byte register data. The host sends ACK after reading 2 bytes of data, and the chip will send PEC bytes. If the host gives NACK, the chip will not send PEC bytes. See the figure below for the detailed operation flow including PEC.

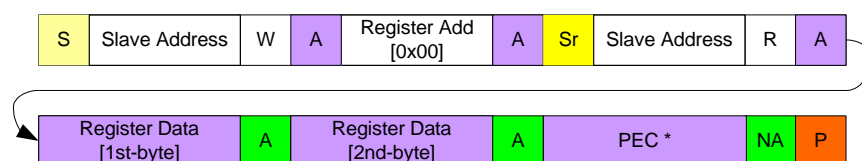

Assuming 1st Slave Address = 0x80h, Register Address = 0x00h, 2nd Slave Address = 0x81h, Register Data (1st-byte) = 0x19h, Register Data (2nd-byte) = 0xE0h, PEC = 0xE6h. PEC = CRC (0x80, 0x00, 0x81, 0x19, 0xE0) = 0XB3h.

Low Voltage Digital Humidity and Temperature Sensor

1.4.7 Read/Write Operation

The chip supports basic standard protocols of Read, Write operation, shown as below figures. For CHT8310, all register data is 16bit, 2-Bytes format.

Read Operation, host generates start 'S' signal in first, then sends slave address (R/W bit=0) of the chip set by user, the chip will ACK the slave address by pull SDA low, then host sends register address, the chip will acknowledge,. Host will generate re-start 'Sr', then send slave address again (R/W bit=1), the chip will ACK again, the output 16-bit (2-Bytes) data with MSB first, then LSB, host have to ACK the MSB byte. Then host send ACK or NACK with stop 'P' at last.

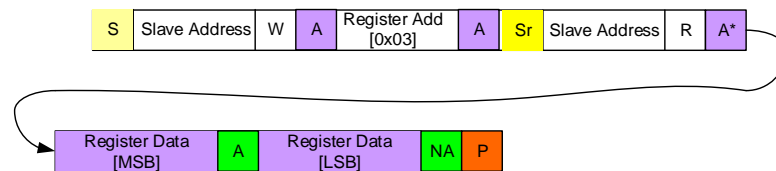

Read (2-Bytes) Operation Figures

Write Operation, host generates start 'S' signal in first, then sends slave address (R/W bit=0) of the chip set by user, the chip will acknowledge the slave address by pull SDA low, then host sends register address. The chip will acknowledge. Host will send 16-bit (2-Bytes) data to be write with MSB first, then LSB, the sensor will ACK byte by byte. Then host send stop 'P' at last.

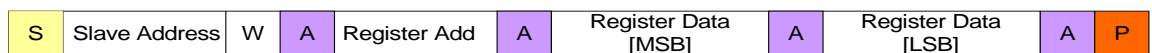

Write (2-Bytes) Operation Figures

2 Application Information

In order to correctly and accurately sense the ambient temperature and humidity, the chip should be kept away from heat sources, RF module and big size components on the PCB. Also to minimize the error caused by self heating it is recommended to measure at a maximum sample rate of 1mps (1 time measurement per second) (H + T). In general application, 0.5mps or even lower monitoring frequency of humidity and temperature is still enough.

2.1 Typical application in hardware

For the sensor, voltage range (Vcc) can be applied by 1.35V to 5.0V. The formula is shown as below. It is necessary to use 4.7k pull-up resistors for I²C Bus (SDA, SCL pin). If I²C bus is available in system, which means pull-up resistors have been placed, just connect SDA, SCL pin of the sensor to the bus respectively. It needs another pull-up resistor (4.7k) for ALERT pin, due to open drain structure. For AD0 pin, it is ok to connect to GND, or Vcc or SDA, or SCL pin directly.

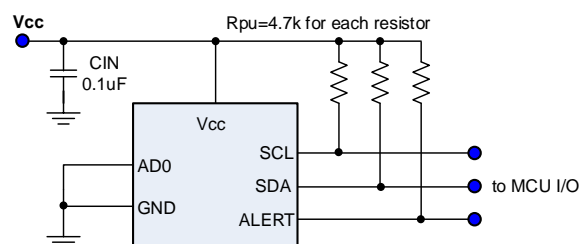

Figure 15. Sensor typical application

Low Voltage Digital Humidity and Temperature Sensor

2.2 PCB Layout

Cautions below are important to improve temperature and humidity measurement accuracy in PCB layout design.

2.2.1 Device placement

The sensor has to be located on the top side of the PCB. It is recommended to isolate the sensor from the rest components of the PCB by eliminating copper layers below the device (GND, V_{cc}) and creating a slot into the PCB around the sensor to enhance thermal isolation. It is better to place the sensor away from any thermal source (e.g. power device in board), high speed digital bus (e.g. memory bus), coil device (e.g. inductors or transformers) and wireless antenna (e.g. Bluetooth, WiFi or RF). It is better to keep the sensor be perpendicular to the ground to prevent dust drop into the cavity. Another important thing is to keep the sensor be good air circulation with environment to be measured.



Figure 16. Sensor placement example at PCB

2.2.2 Cin, Pull-up resistor

It is better to place C_{in} as close as possible to V_{cc} and GND pins of the chip. The recommended C_{in} value is 0.1uF with low ESR ceramic cap although using multi caps, such as 1.0uF plus 0.1uF or 0.01uF, is ok, which can suppress digital noise with different frequency range. User has to put a pull-up resistor with 4.7k to 10k for SDA, SCL and ALERT pins respectively. For AD0 pin, it can be connected to GND, V_{cc}, SDA or SCL pin directly to assign different slave address, see above table.

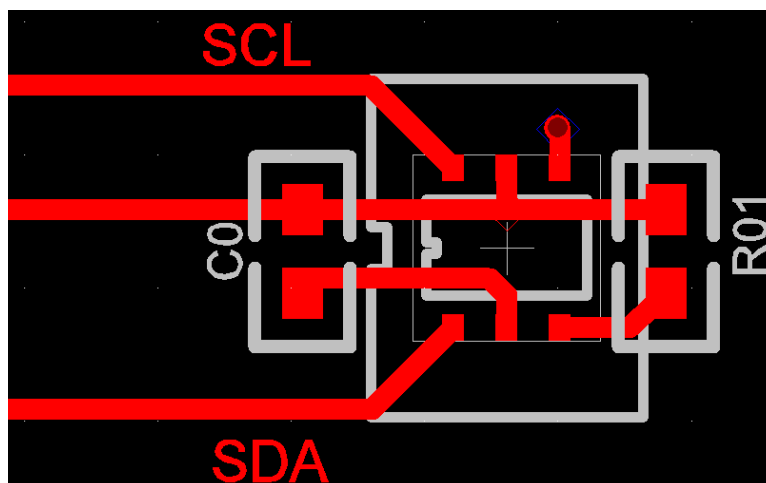

Figure 17. Sensor PCB layout example

Low Voltage Digital Humidity and Temperature Sensor

2.3 Important Notices

It is important to avoid the probability of contaminants coming into contact with the sensor through the open cavity. Dust and other particles as well as liquids could affect the humidity reading data. Also it is recommended to be far away from Vcc, which could cause data drift of humidity reading. However the sensor could recovery after couple minutes once keep away of environment. DO NOT touch the surface of sensor area by inserting hard solid needle into cavity, like tweezers, which could permanently damage the sensor.

2.3.1 Soldering

The CHT8310 chips shipped from the factory is vacuum-packed with an enclosed desiccant to avoid humidity accuracy offset during storage and to prevent moisture issues during solder reflow. The following procedure is recommended during PCB assembly: This sensor chip is compatible with standard board reflow assembly process. It is recommended to use 'No Clean' solder reflow process to reduce water or solvent rinsing impact. If cleaning is have to do after reflow, it is better to order the chip with cavity protection cover, see ordering information for detail. The humidity data of the sensor could be lower if reading immediately after reflow. However it will come back to normal after hydration. Do not exceed 300°C over 10s during reflow or manual handling, which could damage the sensor permanently. For detail about baker conditions, please contact Sensylink sales.

2.3.2 Cavity Protection Cover

The cavity protection cover for CHT8310 is available for order with postfix 'C'. it sticks the chip surface and cover the cavity totally. It is NOT necessary to remove this cover after reflow process. It is very effective to block dust and liquid down to 0.40 microns in size. Below is cavity sample with 3 rows by 4 columns.

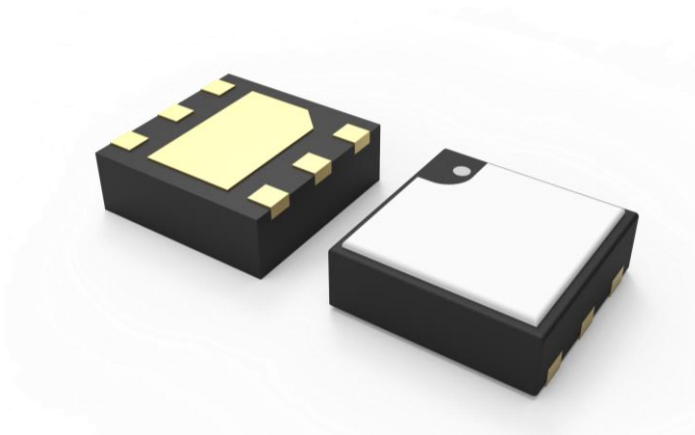

2.4 Software Reference Code

Below lists important function software code based on C- language, which is a reference for user.

```

1. #define ei();           EA=1;
2. #define di();         EA=0;
3. #define U8    unsigned char
4. #define U16   unsigned int
5. sbit  SDA     =  P0^ 0;
6. sbit  SCL     =  P0^ 1;
7. unsigned char cht8310_temp_h,cht8310_temp_l;
8. unsigned char cht8310_humi_h,cht8310_humi_l;
9. unsigned int  cht8310_temp;
10. unsigned int  cht8310_temp;
11.
12. void iic_start(void);
13. void iic_stop(void);
14. void writex(U8 val);
15. U8 readx(void);
16. bit Check_ACK(void);
17. U8 I2C_Read (unsigned char dev);
18. void delay(unsigned char t);
19. extern void delay_tm(unsigned char t);
20. void set_ACK(U8 val);
21.
22. void iic_start(void)
23. {
24.   SDA=1;
25.   delay(1);
26.   SCL=1;
27.   delay(5);
28.   SDA=0;
29.   delay(5);
30.   SCL=0;
31.   delay(5);
32. }
33.
34. void iic_stop(void)
35. {
36.   SDA=0;
37.   delay(1);
38.   SCL=1;
39.   delay(5);
40.   SDA=1;

```

Low Voltage Digital Humidity and Temperature Sensor

```
41.     delay(5);
42. }
43.
44. void writex(U8 val)
45. {
46.     U8 i;
47.     for (i=0;i<8;i++)
48.     {
49.         SDA=val&0x80;
50.         delay(1);
51.         SCL=1;
52.         val<<=1;
53.         delay(5);
54.         SCL=0;
55.         delay(8);
56.     }
57. }
58.
59. U8 readx(void)
60. {
61.     U8 i,val=0;
62.     SCL=0;
63.     delay(1);
64.     SDA=1;
65.     for (i=0;i<8;i++)
66.     {
67.         SCL=1;
68.         val=val<<1;
69.         if (SDA==1) val |=0x01;
70.         delay(4);
71.         SCL=0;
72.         delay(3);
73.     }
74.     return val;
75. }
76.
77. bit Check_ACK(void)
78. {
79.     SDA=1;
80.     delay(1);
81.     SCL=1;
82.     delay(7);
83.     if(SDA==1)
```

Low Voltage Digital Humidity and Temperature Sensor

```
84.     {SCL=0; delay(6);return 1;}
85.     else
86.     {SCL=0; delay(6);return 0;}
87. }
88.
89. void  set_ACK(U8 val)
90. {
91.     if(val==1)
92.         SDA=1;
93.     else
94.         SDA=0;
95.     SCL=1;
96.     delay(7);
97.     SCL=0;
98.     delay(7);
99. }
100.
101.
102.U16 I2C_Read_Word(unsigned char adr)
103.{
104.    U16 val=0;
105.    iic_start();
106.    writex(0x80);
107.    if(Check_ACK())
108.        return 0;
109.    writex(adr);
110.    if(Check_ACK())
111.        return 0;
112.    delay_tm(1);
113.
114.    iic_start();
115.    writex(0x81);
116.    if(Check_ACK())
117.        return 0;
118.    val=readx();
119.    val<<=8;
120.    set_ACK(0);
121.    val|=readx();
122.    set_ACK(1);
123.    iic_stop();
124.    return val;
125.}
126.
```

Low Voltage Digital Humidity and Temperature Sensor

```
127. void delay(U8 t)
128. {
129.   while(t--);
130. }
131.
132. void main()
133. {
134.   float cht8310_temp=0.0;
135.   float cht8310_humi=0.0;
136.   U16   temp_val,humi_val;
137.   Init_io_port();
138.   while(1)
139.   {
140.     temp_val=I2C_Read_Word(0);
141.     cht8310_temp=(float)(temp_val>>1)/128.0;
142.     humi_val=I2C_Read_Word(1);
143.     cht8310_humi= (humi_val&0x7fff)/ 32768.0 * 100;;
144.     printf("current temperature is: %.8f °C\n",cht8310_temp);
145.     printf("current Humidity is: %.8f °C\n",cht8310_humi);
146.   }
147. }
```

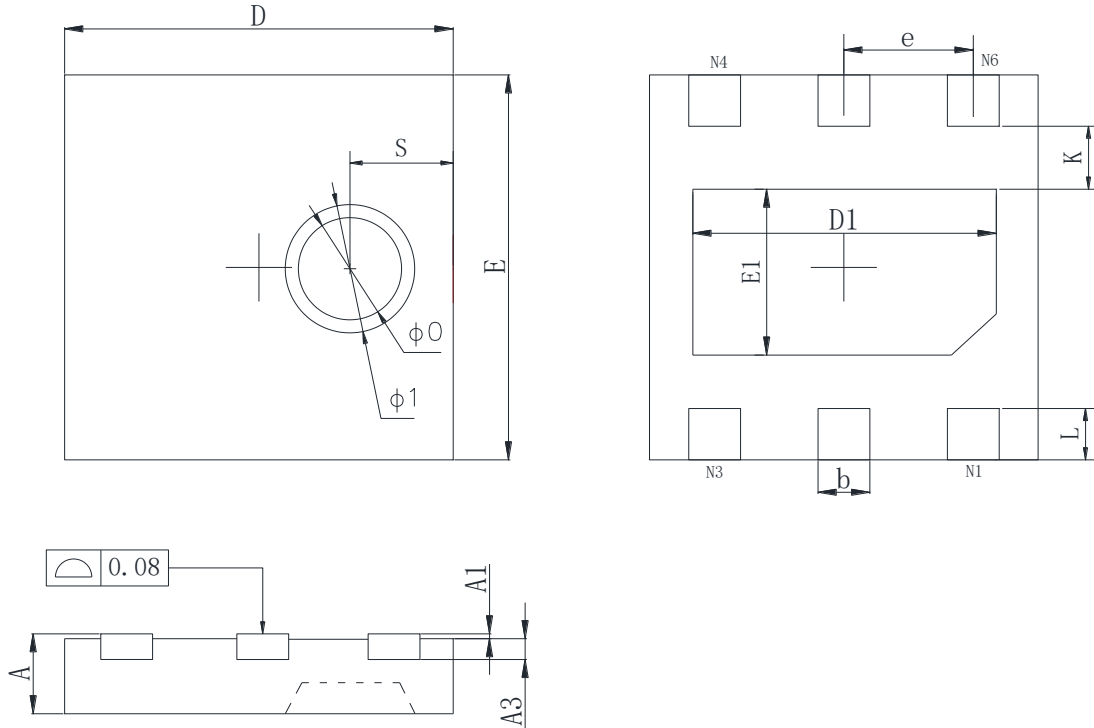
Package Outline Dimensions (DFN3x3-6)
DFN3x3-6 Unit (mm)

Symbol	Dimensions in Millimeters		Dimensions in Inches	
	Min.	Max.	Min.	Max.
A	0.900	1.100	0.035	0.043
A1	0.010	0.050	0.000	0.002
A3	0.203REF.		0.008REF	
D	2.900	3.100	0.114	0.122
E	2.900	3.100	0.114	0.122
D1	2.300	2.500	0.091	0.098
E1	1.400	1.600	0.055	0.063
k	0.350MIN.		0.014MIN	
b	0.350	0.450	0.014	0.018
e	1.000TYP.		0.040TYP	
L	0.350	0.450	0.014	0.018
S	0.740	0.840	0.029	0.033
$\phi 0$	0.800TYP		0.036TYP	
$\phi 1$	1.000TYP		0.040TYP	

Note: Pin1 shape on backside is not limited to bevel, it can be a notch or arch

Recommend Land Pattern Layout (DFN3x3-6)

DFN3x3-6 Unit (mm)

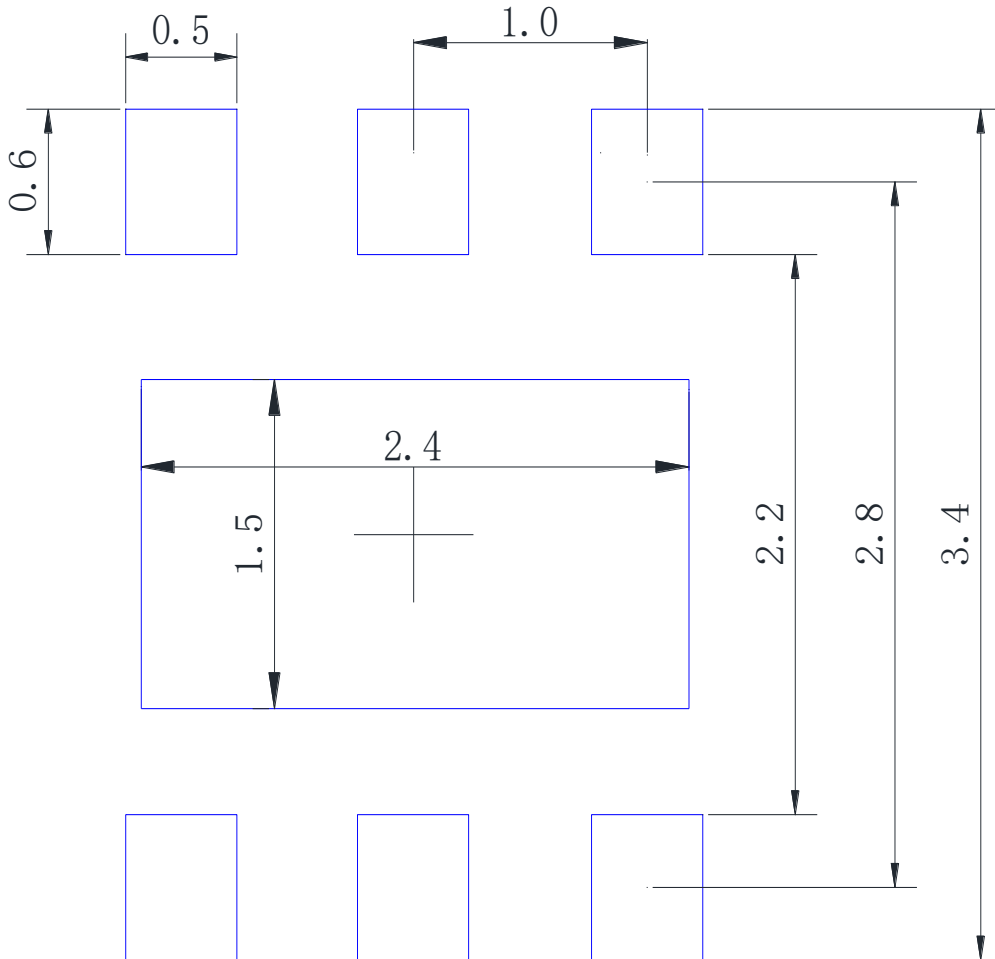

Note:

1. All dimensions are in millimeter
2. Recommend tolerance is within ± 0.1 mm
3. If the thermal pad is not necessary, designer can leave the land pattern area blank
4. Change without notice

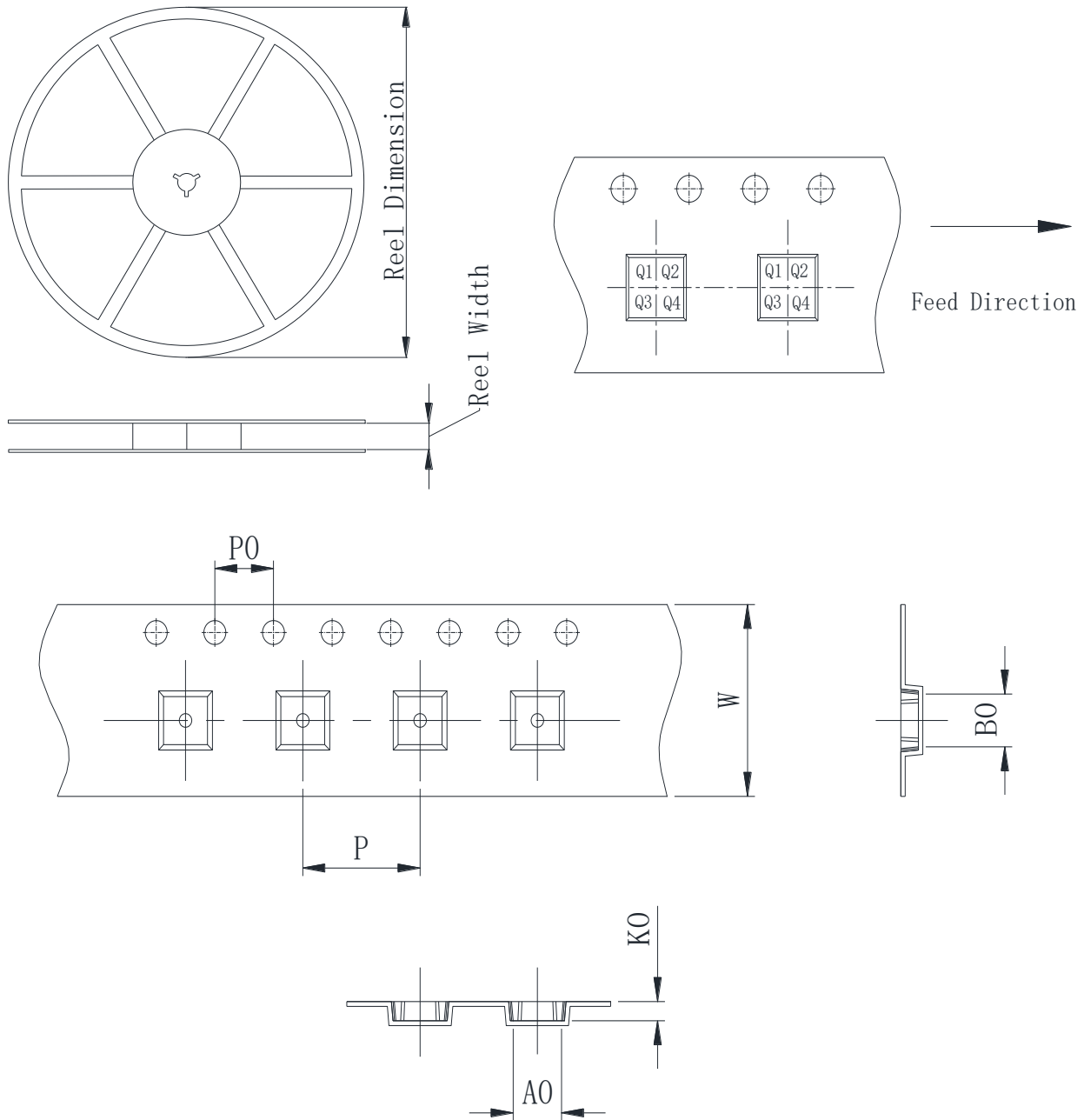
Packing information

Package type	Reel size	Reel dimension ($\pm 3.0\text{mm}$)	Reel width ($\pm 1.0\text{mm}$)	A0 ($\pm 0.1\text{mm}$)	B0 ($\pm 0.1\text{mm}$)	K0 ($\pm 0.1\text{mm}$)	P ($\pm 0.1\text{mm}$)	P0 ($\pm 0.1\text{mm}$)	W ($\pm 0.3\text{mm}$)	Pin1
DFN3x3-6	13'	330	12.5	3.5	3.5	1.2	8.0	4.0	12.0	Q4

Low Voltage Digital Humidity and Temperature Sensor**Revision History**

Version	Date	Change Content
Ver1.0	2023/4	Initial Version
Ver1.1	2023/9	Modify PEC description

***SENSYLINK Microelectronics Inc.***

www.sensylink.com

IMPORTANT NOTICE

SENSYLINK Microelectronics Inc. reserves the right to make modifications, enhancements, improvements, corrections or other changes without further notice to this document and any product described herein or to discontinue any product or service. Customers should obtain the latest relevant information before placing orders and should verify the latest and complete information. SENSYLINK Microelectronics does not assume any responsibility for use of any product, nor does SENSYLINK Microelectronics any liability arising out of the application or use of this document or any product or circuit described herein. SENSYLINK Microelectronics assumes no liability for applications assistance or the design of Customers' products. Customers are responsible for their products and applications using SENSYLINK Microelectronics components. SENSYLINK Microelectronics does not convey any license under its patent or trademark rights nor the other rights.

SENSYLINK Microelectronics Inc. © 2015 - 2023.